



Taylor Davis
...not just ANY packaging company!

Product Specification Sheet

Product Category: **DRUMS & KEGS**

Product Title: **POLYDRUM 60L UN TIGHTHEAD - BLUE**

Product Code: **PP60-0L002**

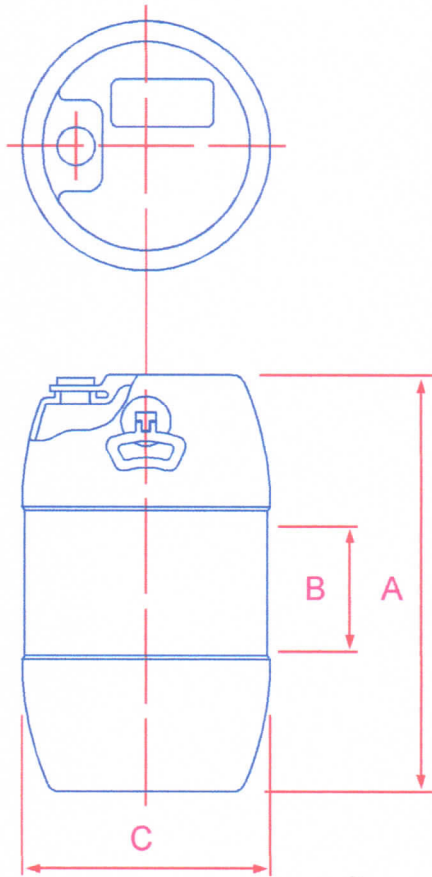

Dimensions	(mm)
Overall Height 'A'	613 ± 3
Recessed Centre Flat Panel 'B'	180 ± 1.5
Diameter 'C'	400 ± 3.0

* These figures only apply when the drums are filled to 98% of their capacity and are stacked on double deck, flush pallets. The bottom deck must cover at least 80% of top deck area.

** Alternative gaskets may be provided for special applications.

Vented bungs can be offered with either umbrella or PTFE microporous vents, but the UN certificate is not longer applicable unless stated

BODY			
Material	High density, high molecular weight polyethylene		
Fabrication	Extrusion blow moulded		
Nominal/Brimful Capacity (L)	60/63		
Body mass (kg)	2.8 +/-0.1		
Minimum Thickness (mm)	2.2		
Stacking height up to 25° C with Contents up to rd.	4 High* Group II, 2.1 RD ,Group I ,1.4 RD		
UN & RID/ADR Certificates – Standard Liquids	Packing Group	Relative Density	
- Water	LI	1.4	
- Wetting Agent			
- Nitric Acid			
- White Sprit			
- Butyl Acetate			
L – Lupolen	1H1/X1.4/250/** /GB/0985		
CLOSURE SYSTEM			
Position	Centre of bung 50mm from edge of drum on mould part line		
	BCS 56 x 4		
Internal Thread Diameter (mm)	Major	57.9 ± 0.2	
	Minor	52.7 ± 0.2	
External Height (mm)	25		
Thread	Buttress	Pitch (mm)	4
Bung	Euro 56x4		
Material	High density polyethylene		
Gasket	EPDM**		
Closing Torque (Nm)	18 ± 2		
Capseal	Plastic (snap-on)		
Handles	3		
FINISH			
Drum body colour	Blue		
Closure colour	White		
Customer requirements	Shrink-wrapped in packs of 18		