



Taylor Davis
...not just ANY packaging company!

Product Specification Sheet

Product Category: **PLASTIC JARS**

Product Title: **JAR 750ML (110X90) T/E 8401901 - WHITE**

Product Code: **JB0750M002**

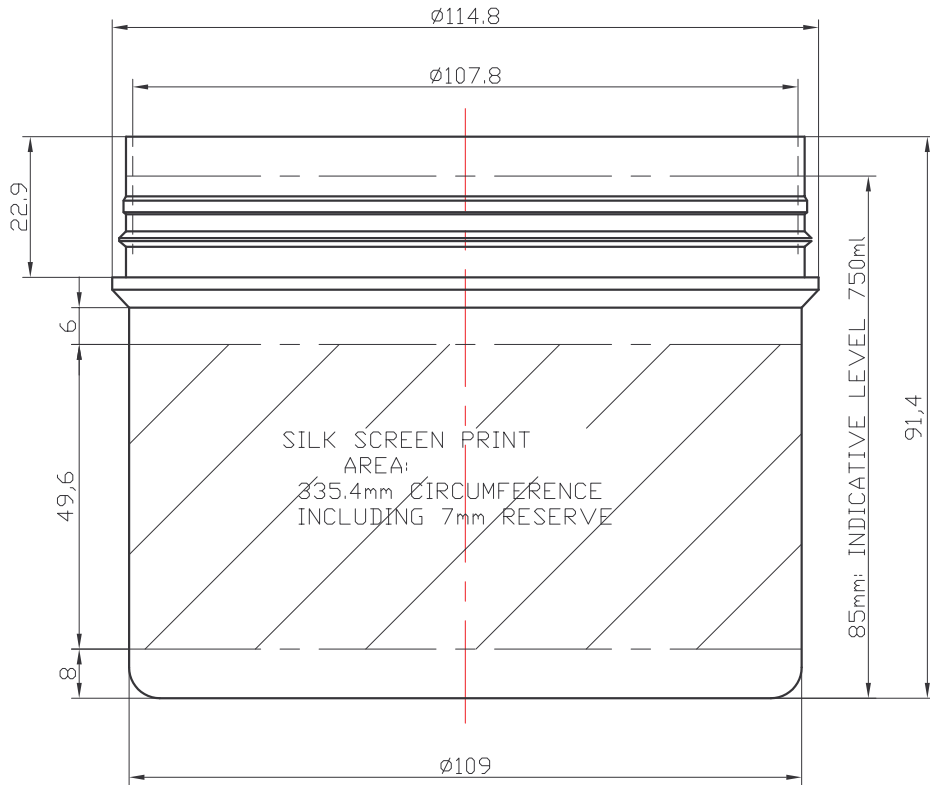

DIMENSIONS	TOL.
$a < 10$	± 0.3
$10 < a < 25$	± 0.4
$25 < a < 50$	± 0.55
$50 < a < 75$	± 0.83
$75 < a < 150$	± 1.15
$150 < a < 200$	± 1.5
$200 < a < 250$	± 1.8

A	26.03.04	DESIGNATION: PBT INVIO BECOMES SNAPLOCK JAR	
ISSUE	DATE	MODIFICATIONS	
ALL REPRODUCTION OR COMMUNICATION OF THIS INFORMATION TO A THIRD PARTY IS STRICTLY FORBIDDEN WITHOUT PROMENS WRITTEN AUTHORISATION			
		SNAPLOCK JAR 110x90 (750ml)	
		REFERENCE: 84019..	
		CUSTOMER: STANDARD	
DRAWN: N.M.	DATE: 26.04.01	RAW MATERIAL: PP	
CHECKED: MG	DATE: 23.11.07	WEIGHT: 56.2 \pm 2.5g	
SCALE: 1	ISSUE: A	BRIMFUL CAPACITY: 798 \pm 20ml	
		DRAWING NUMBER: WEB-01_084	