



Taylor Davis
...not just ANY packaging company!

Product Specification Sheet

Product Category: Plastic Jars

Product Code: JB0155M001

Optima Screw Top Jar - 155ml

JB0155M001

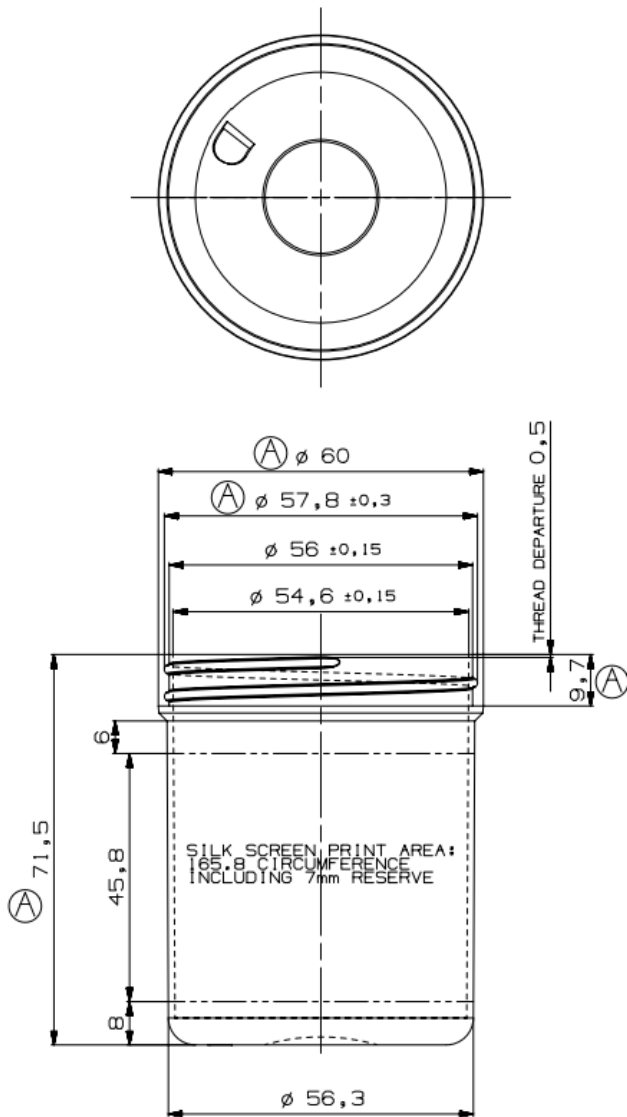

PITCH=5
1.25 TURNS OF THREAD

SEE NFT 58000 NORM NORMAL CLASS
ON DIMENSTIONS WITHOUT TOLERANCE

A	22.08.13	$\varnothing 60, \varnothing 57,8 \pm 0,3, 9,7, 71,5$ WERE $\varnothing 60,9, \varnothing 57,8 \pm 0,15, 9,5, 72,1$	
ISSUE	DATE	MODIFICATIONS	
ALL REPRODUCTION OR COMMUNICATION OF THIS INFORMATION TO A THIRD PARTY IS STRICTLY FORBIDDEN WITHOUT PROMENS WRITTEN AUTHORISATION			
OPTIMA JAR 55x70 (155ml)			REFERENCE: 80016..
DRAWN : NMY CHECKED: BBX SCALE: 1:1	DATE : 02.07.13 DATE : 26.08.13 ISSUE : A	RAW MATERIAL : PP WEIGHT : $15,5 \pm 0,6g$ BRIMFUL CAPACITY : $162 \pm 3ml$	CUSTOMER: STANDARD DRAWING NUMBER: WEB 13_066