



Taylor Davis
...not just ANY packaging company!

Product Specification Sheet

Product Category: **PLASTIC JARS**

Product Title: **JAR 100ML (50X60) SC/TE 8601601 - WHITE**

Product Code: **JB0100M002**

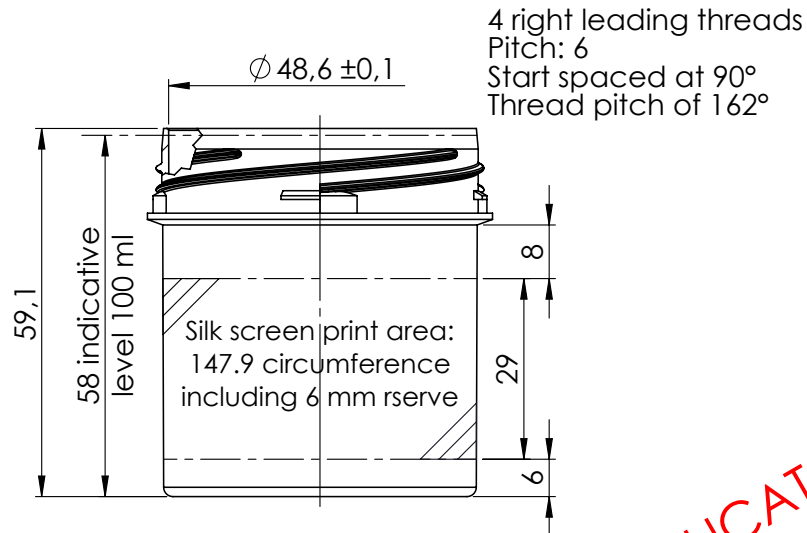
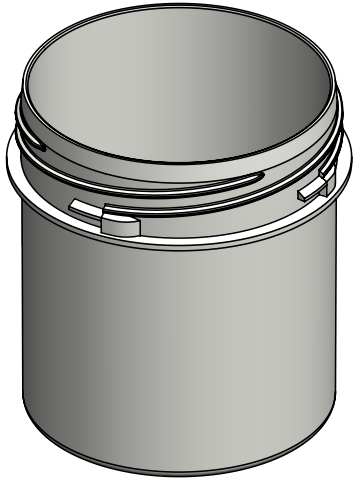

DUPLICATA

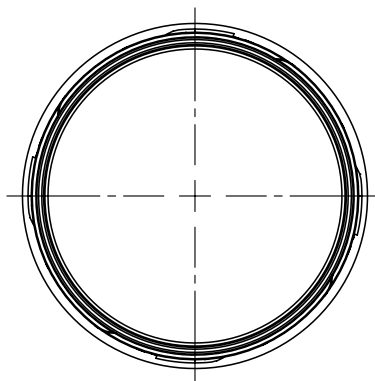

| | | | | |
|--|----------|---|---|--------------------------|
| C | 23/03/04 | Designation Screwlock jar 50x60 was PVI 50x60 | NIMA | - |
| Issue | Date | Modifications (see historic at back) | Modified | Checked |
| | | Designation: Screwlock Jar 50x60 100 ml | Drawn by: NIMA | Date: 20/03/2001 |
| | | Raw material: PP | Checked by: MAGE | Date: 23/01/2008 |
| | | Brimfull capa.: 104±3ml | Reference: 86016.. | Drawing n°: WEB-94076 |
| | | Weight: 12±0.6g | | |
| | | Scale: 1:1 | Standard for dimensions without tolerances: NFT 58 000 Normal class | |
| ALL REPRODUCTION OR COMMUNICATION TO THIRD PARTY IS STRICTLY FORBIDDEN WITHOUT BERRY WRITTEN AUTHORISATION | | | | |