



Taylor Davis

...not just ANY packaging company!

Product Specification Sheet

Product Category: **PLASTIC JERRICANS**

Product Title: **JCAN UN 15L 60MM - NATURAL**

Product Code: **HB15-0L001**

Available Weights: 800 ±010g

Brimful Capacity : 17000±400ml

Material: **HDPE**

All dimensions are in mm

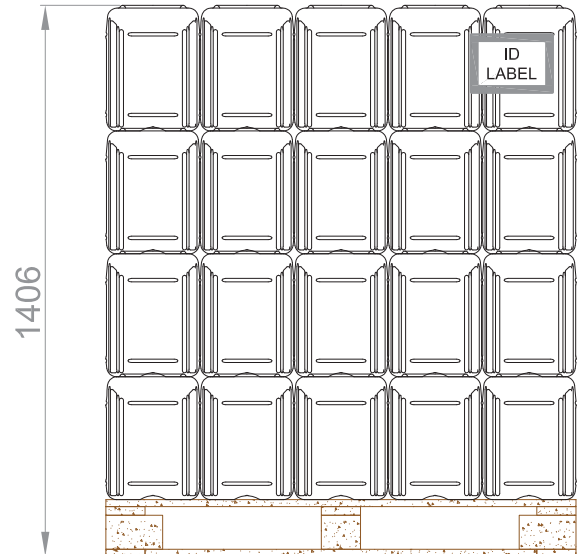
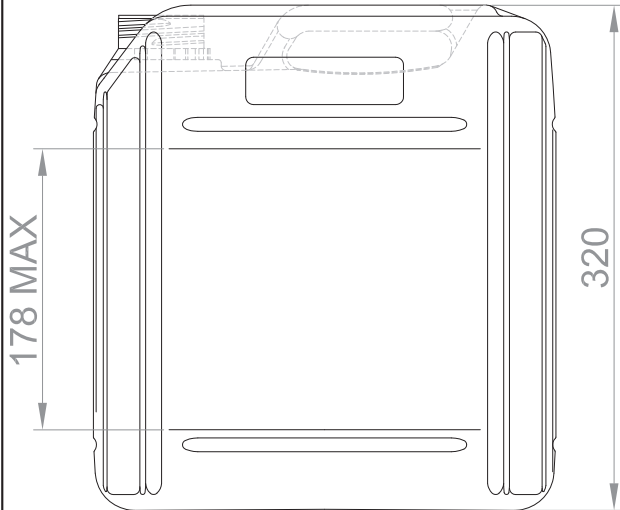

PALLET 1200 x 1000mm

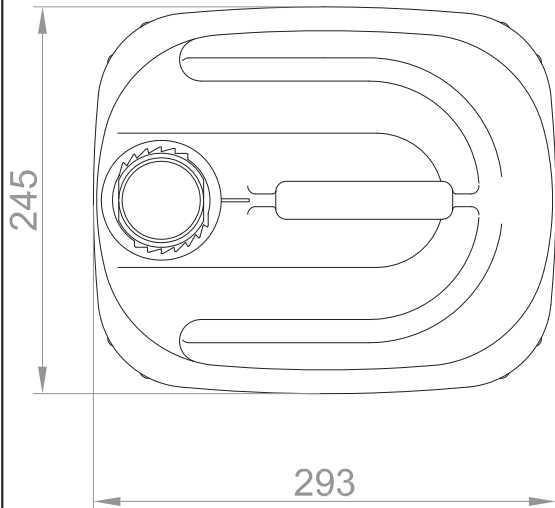

17 containers per layer

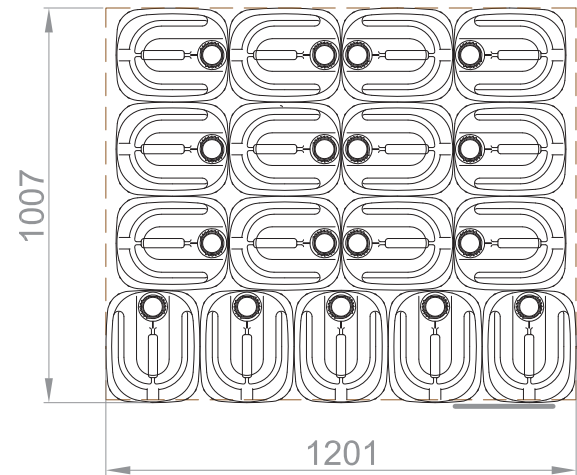

Base Markings: *Cavity number, Date, "F" when Fluorinated, "C" when Conventional*

Cap Options: *60mm Tamper Evident*

Wad Options: *PET / ALU / EPE, IHS or Tresylene*

UN Certification: *For Combined or Freestanding following the density of your products, please contact us*

Gross Weight Approx: *Including Pallet, 76 kg*

Quantity / Pallet: *68*

Quantity / Lorry: *3536 (52 Pallets) bottles only, 3400 (50 Pallets) bottles and caps*